

ArmAnDo

Multifunctional Turntable



ArmAnDo is designed to enhance productivity and efficiency in industrial production. It serves as a platform for a collaborative robot (cobot) to operate multiple machines in turn. By utilizing the turntable, the cobot can easily switch between different tasks and perform various operations without the need for manual intervention.

In addition to its primary function as a turntable, the ArmAnDo conveyor can be integrated with a mobile robot (ex. Omron LD-series). The LD's efficiently delivers raw materials to the turntable and retrieves finished products. This integration streamlines the production process, eliminates the use of manual labor, and optimizes the workflow.

Efficient. Accurate. Safe.

- Reduces manual labor
- Cobot operated
- Mobile Robot integration
- Easy access HMI
- Accuracy - 0,01 mm
- Repeatability - 0,02 mm
- Rotation speed - 0,83 r/m
- 360° Safety Scanners

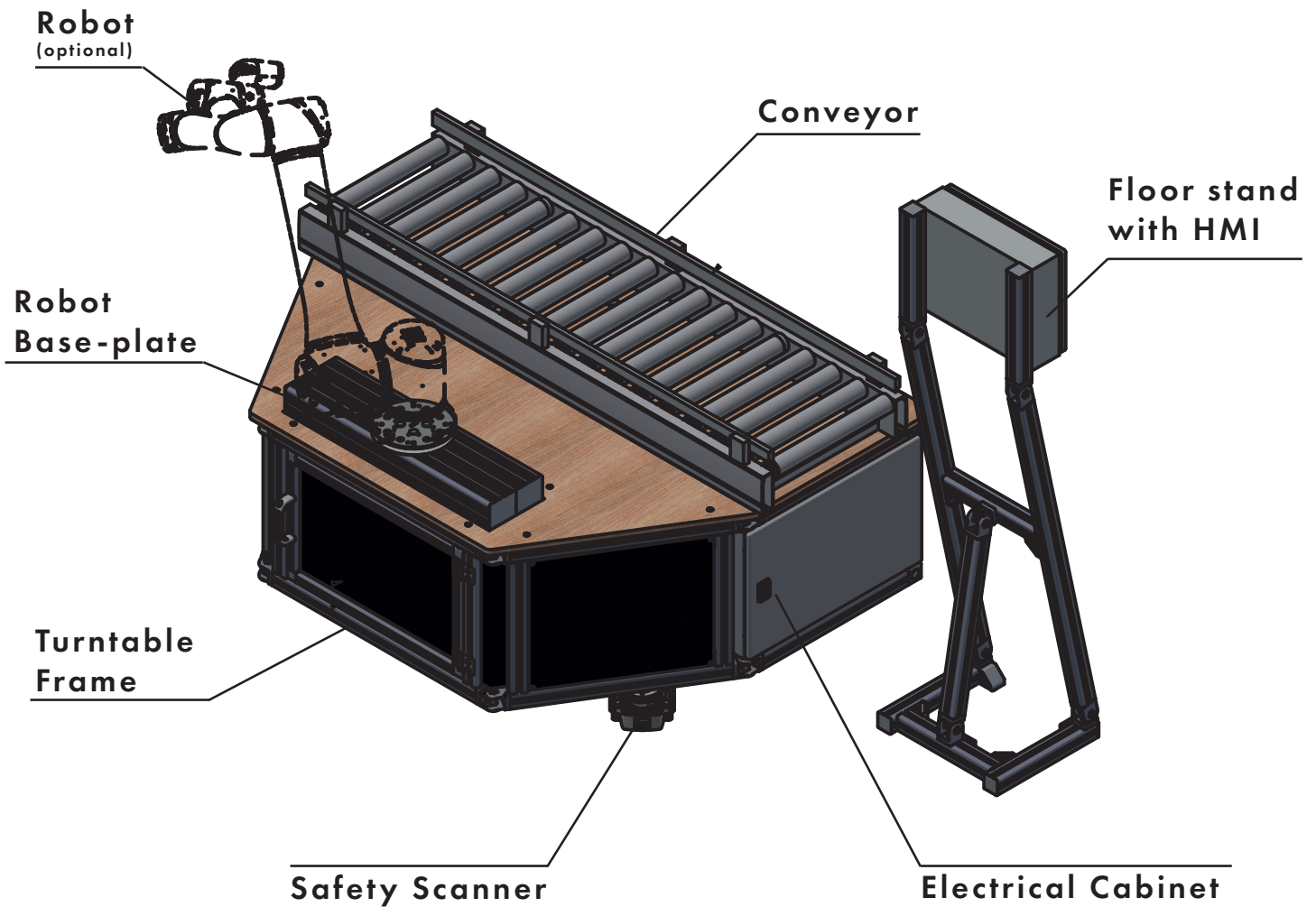

GENERAL

Item No	-
Type	Multifunctional Turntable
Designed use	Rotating Table w/ Conveyor & Cobot-base
Power	3x 400V/ 50 Hz/ 16A
Accuracy	0,01 (mm)
Repeatability	0,02 (mm)
Table rotation speed	0,83 (r/m)
Sound pressure level	<80 dB

DIMENSIONS (≈)

Lenght	1600 mm.
Width	1200 mm.
Height	800 mm.
Weight	600 kg.

SAFETY

Scanners	Yes
Closed Cabinet	Yes
Ingress protection	IP20